

DCOW Capacitive leakage detectors of the LeUk7 UdUWj Y range with sensor and relay

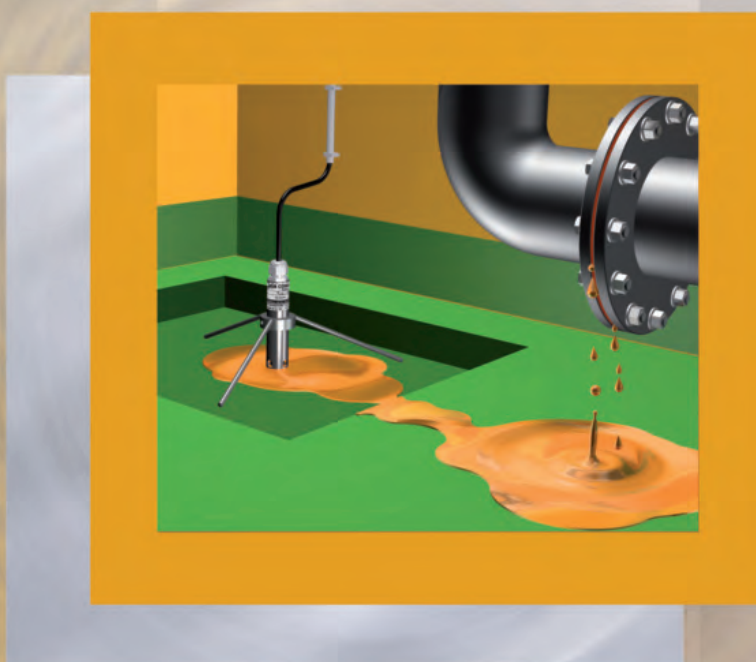

Capacitive leakage detectors of the LeUk7 UdUWijj Y range - General

- with integrated cable break monitoring
- for signalling the presence of electrically non-conductive low-viscosity liquids on the floor of normally dry collection rooms or collection tubs, for example for signalling the presence of fuel oil on the floor of a normally dry tank room or in a collection tub underneath a fuel oil burner

Use of an DOWE 2/C capacitive sensor with mounting stand for detection of a leakage in a collection tub underneath a fuel oil burner

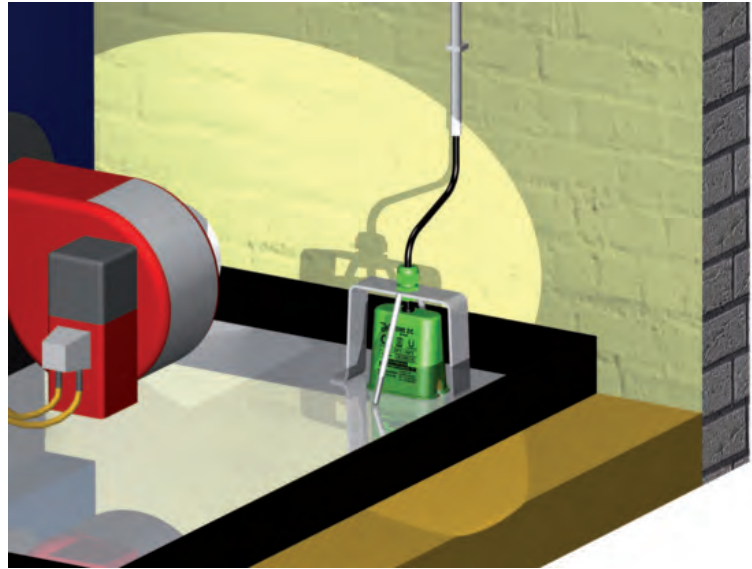

The LeakCapactive leakage detectors consist of:

- one or several **DCPE**, **DOWE 2/C** or **DCOW** capacitive sensor(s) and
- a **LeUkCapactive101** or **LeUkCapactive 155** capacitive relay.

Only one DCPE, DOWE 2/C or DCOW capacitive sensor is destined for connection to a LeakCapactive 101 capacitive relay.

Up to 5 capacitive sensors can be connected to a LeakCapactive 155 capacitive relay.

The **DCPE** sensor must be installed on the floor in such a way that the sensor side faces downwards and the label side upwards.

The **DOWE 2/C** and **DCOW** sensors can be mounted either

- upright on the floor (using the mounting stand offered by our as an option) or
- freely suspended by their cable above the floor.

The DCPE, DOWE 2/C and DCOW sensors should only be used in normally dry surroundings – e.g. in normally dry collection rooms or collection tubs.

The **LeakCapactive101** relay is designed for DIN rail mounting or fastening via 2 boreholes. The various operating statuses are shown by 3 coloured LEDs.

The **LeakCapactive 155** relay is designed for surface mounting. The various operating statuses are shown by 5 x 3 coloured LEDs.

Areas of application:

All organic and inorganic liquids with specific dielectric constants between 2 (DCPE) or 1.8 (DOWE 2/C and DCOW) and 109.

Prerequisite is that these liquids, dependent on the ambient temperature, are present in fluid form, and that the sensors to be used will be sufficiently wetted.

The capacitive measuring principle

The capacitive measuring principle is mainly used for the detection of **electrically non-conductive (insulating) liquids**, but it can also be used to detect electrically conductive liquids.

Electrically non-conductive liquids are generally organic liquids like oils and solvents. An electrode assembly forms a measuring capacitor, and the dielectric is either air or liquid. The dielectric constant of air is 1. The dielectric constant of the liquid to be detected is higher. For our capacitive sensors, the dielectric constant has to be higher than 2 (type DCPE) or 1.8 (types DOWE 2/C and DCOW).

The capacitive leakage detector recognises a change in the dielectric constant at the measuring capacitor and an alarm signal is emitted. The design of the measuring capacitor allows direct mounting on the floor and generally rules out the possibility of interference effects due to different subsurfaces.

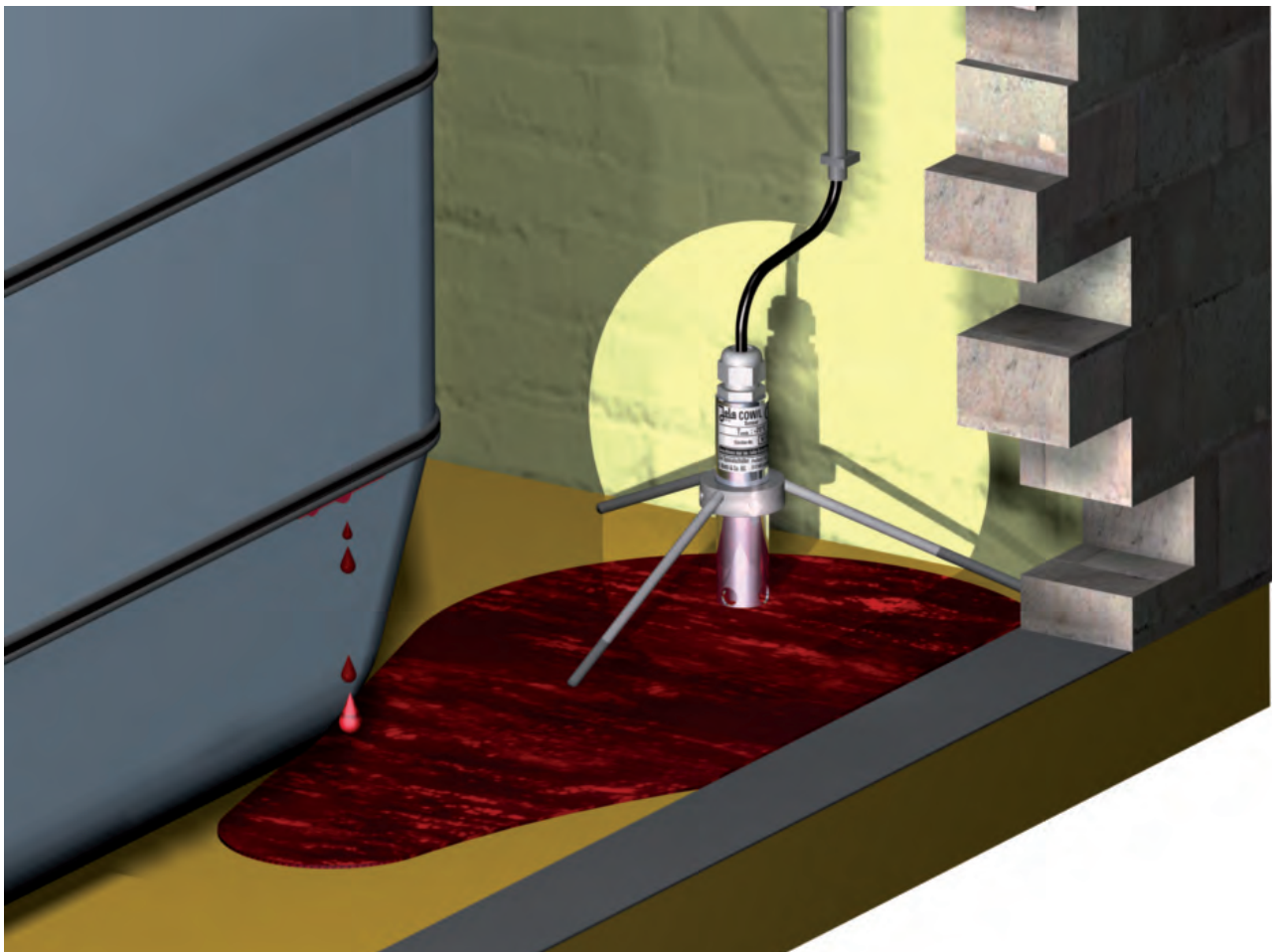

Use of a DCOW capacitive sensor with mounting stand for leakage detection of an oil leakage in a collection room

Application examples with capacitive sensors

Use of a DCPE capacitive sensor for leakage detection of a liquid in a pipe duct

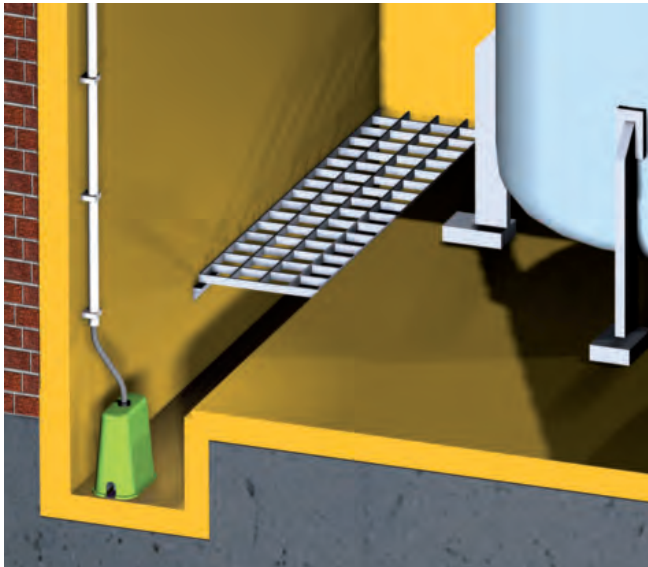
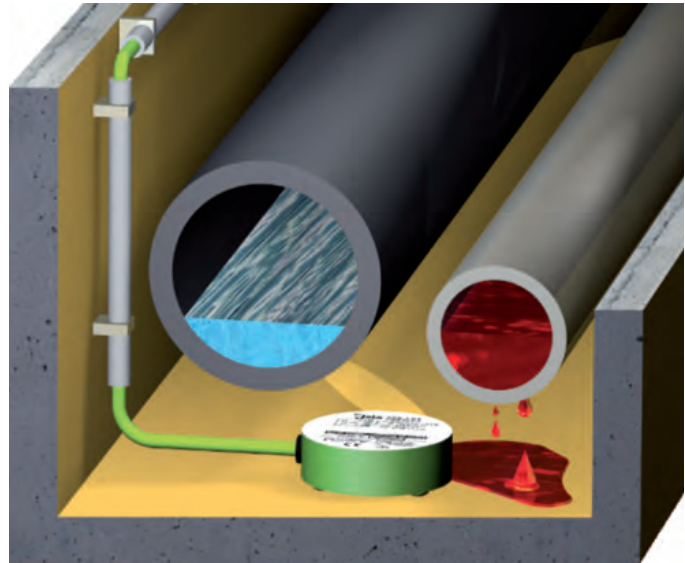

Use of an DOWE 2/C capacitive sensor for leakage detection of a liquid at the lowest point (groove in the picture) of a collection room

Use of a DCOW capacitive sensor for leakage detection in the collection tub of a storage tank for water-polluting liquids

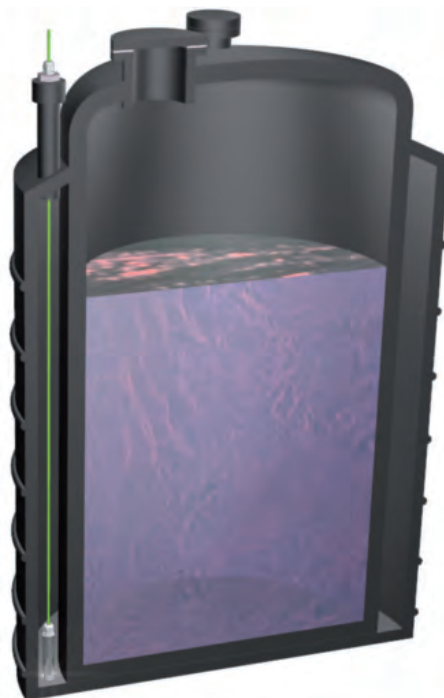

8 COW capacitive sensor

- with housing made of stainless steel 316 Ti

Technical data	8 COW
Housing	stainless steel 316 Ti and PTFE
Electrical connection	TPK cable, 2X0.75 mm ² , length 5 m, on request: <ul style="list-style-type: none"> • longer • made of PTFE
Sensitive elements	a stainless steel housing used as a guard electrode and an inner cylinder used as a measuring electrode form a detection capacitor
Protection class of the electronics sealed in the housing	IP65
Response height from bottom edge of housing	≥ 12 mm (depending on the dielectric constant of the liquid)
Min. required dielectric constant of the liquid to be detected	1,8
Temperature range	- 20°C to + 60°C
Max. length of connecting cable	1,000 m between sensor and relay
EMC	<ul style="list-style-type: none"> • for interference emission in accordance with the appliance-specific requirements for households, business and commerce as well as small companies • for interference immunity in accordance with the appliance-specific requirements for industrial companies
Mounting stand (optional)	stainless steel 316 Ti

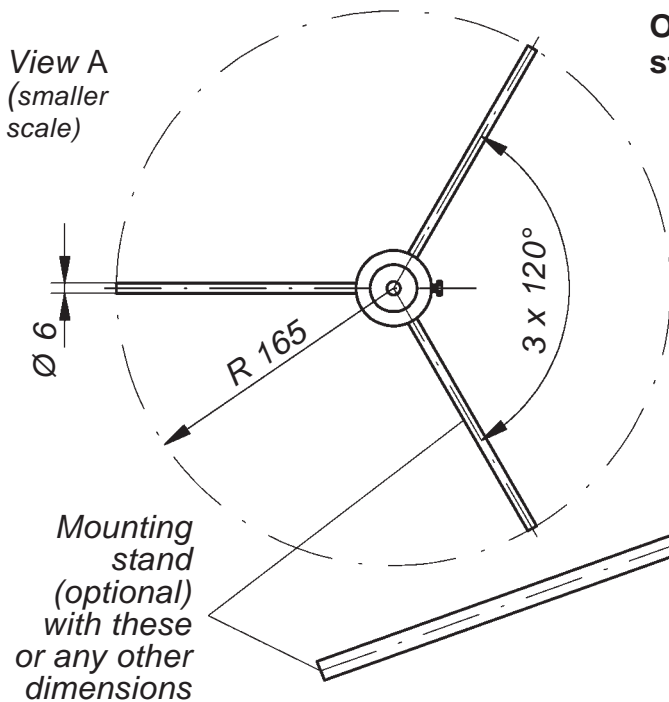
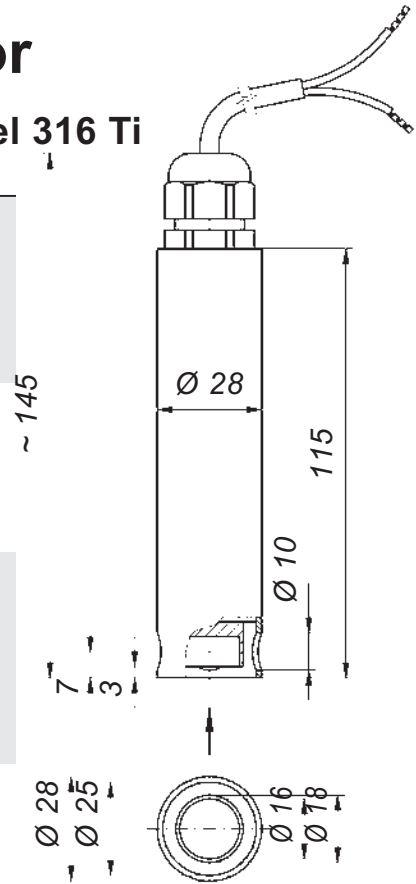

Optional: mounting stand made of stainless steel 316 Ti for DCOW

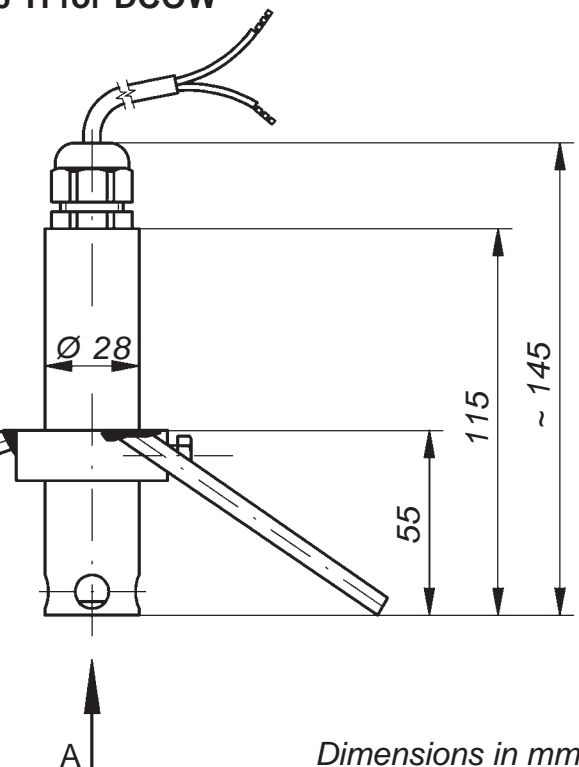

Dimensions in mm

Capacitive sensors

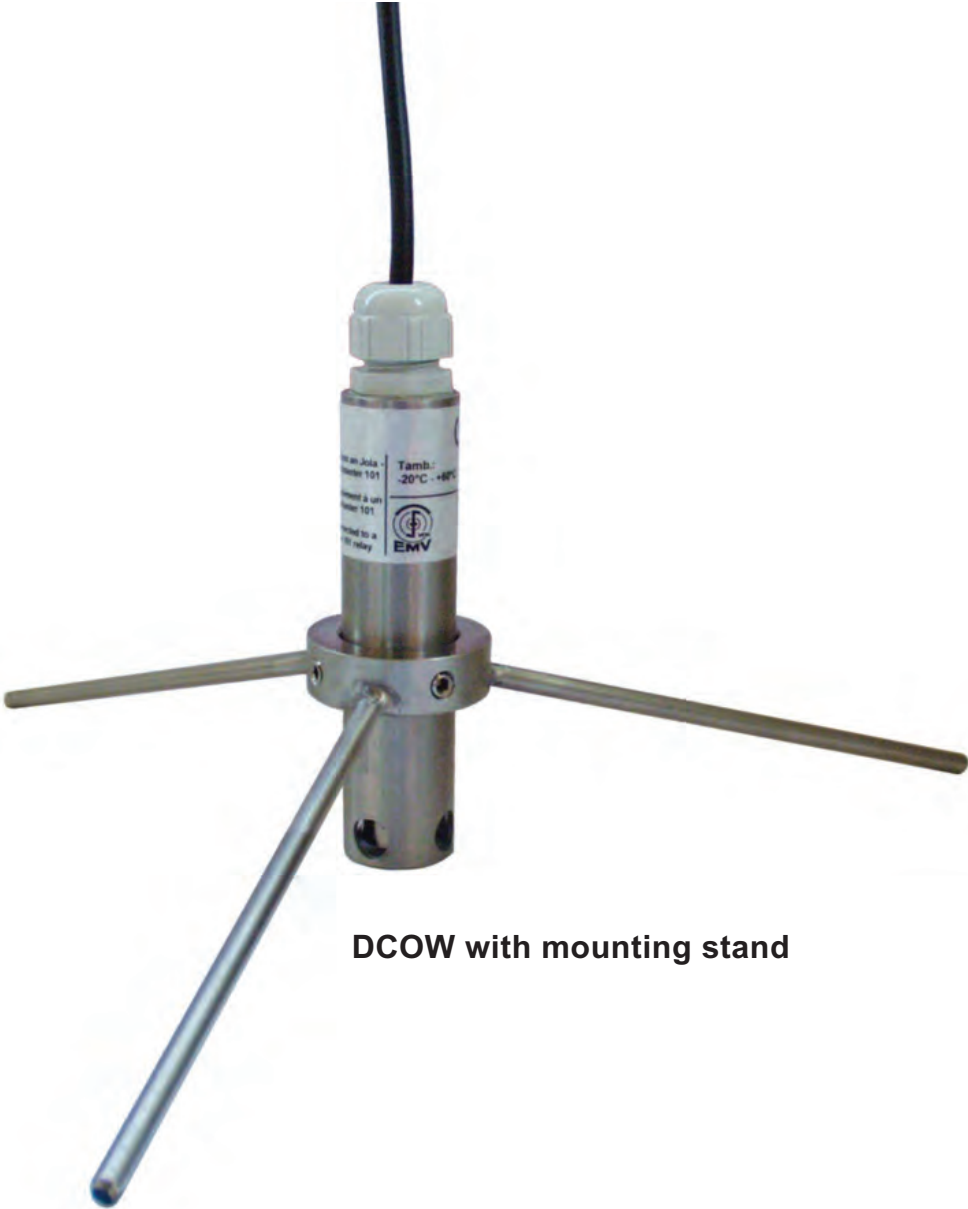

DCOW with mounting stand



DCOW