

Conductive leakage detectors

for the detection of substances like

- Glycol in water
- Acid or lye in water
- Liquid manure in water
- Silage in water



General information on conductive leakage detectors for the detection of substances like

- Glycol in water
- Acid or lye in water
- Liquid manure in water
- Silage in water

37-3-3**8 STK- $\frac{3}{4}$ " conductive rod electrode****37-3-5****GR 3 and GR 5 conductive electrode relays****37-3-7**

The units described in this documentation may only be installed, connected and started up by suitably qualified personnel!

Subject to deviations from the diagrams and technical data.

The details in this brochure are product specification descriptions and do not constitute assured properties in the legal sense.

General information on conductive leakage detectors for the detection of substances like

- Glycol in water
- Acid or lye in water
- Liquid manure in water
- Silage in water

1. Principle

Conductive leakage detectors are generally used to detect and signal the presence of electrically conductive liquids.

A measuring current flows via the electrically conductive liquid between the two electrode rods of a rod electrode and activates a switching command in the corresponding electrode relay.

The size of the measuring current depends on the specific conductivity and the temperature of the liquid, the applied measuring voltage and the geometry of the electrode rods.

One criterion for the differentiation of liquids is the differing specific conductivity.

The job of the leakage detectors described here is to detect and signal the presence of a generally water-polluting liquid with a far higher specific conductivity than water with a lower specific conductivity (e.g. condensation, process water, rainwater).

The electrical conductivity of aqueous liquids is highly dependent on their temperature, and an electronic circuit for temperature compensation is therefore integrated in the rod electrode.

2. Recommendation for use

The electrically conductive liquid **not to be recorded** should have a maximum specific conductivity of 250 $\mu\text{S}/\text{cm}$ (by way of comparison, rainwater: approx. 10 ... 100 $\mu\text{S}/\text{cm}$).

The electrically conductive leakage liquid **to be recorded** must have a specific conductivity of at least 1,000 $\mu\text{S}/\text{cm}$. This minimum conductance must be reached in cases where the leakage liquid becomes mixed with low-conductivity water. It is particularly important to take this into consideration with liquids whose conductivity is **not** many times 1,000 $\mu\text{S}/\text{cm}$.

In the case of highly conductive liquids (> 3,000 $\mu\text{S}/\text{cm}$) detection may still be possible with a dilution of 1:10 or even 1:100.

The change in conductivity is not linearly dependent on the degree of dilution but mainly depends on the type of liquid.

Signs that proper functioning is no longer assured, leading to potential false alarms:

- If it is possible that fats and oils are present, the electrode rods may become partially or completely, temporarily or permanently insulated. This means that correct functioning is no longer assured.
- If surface water is present rather than rainwater (the specific conductivity of surface water can reach or even exceed 1,000 $\mu\text{S}/\text{cm}$), it is possible that the resulting higher conductivity may trigger a false alarm.

3. Conductive leakage detectors can or should generally not be used:

- a) With electrically non-conductive liquids (e.g. in mineral oils),
- b) With pulpy or viscous liquids,
- c) With liquids that form foam,
- d) With liquids with a tendency to form deposits (e.g. waste water containing fats),
- e) With liquids with high dirt content, which can clog the electrode rods (e.g. rainwater with leaves, twigs, refuse and sweepings).

4. Electrode relays

A GR 3 or GR 5 electrode relay is to be used with the ÖSTK- $\frac{3}{4}$ " rod electrode. Both electrode relays operate on the quiescent current principle (refers to the relay output).

Before connecting the electrode relay, it is important to check that the mains voltage to be connected to the mains terminals is the same as that stated on the rating label. The built-in transformer steps the mains voltage down to a safe low voltage and transports the voltage via the connected electrode to the relay electronics.

To ensure correct functioning, the three connection wires of the electrode must be connected to terminals E0, E1 and \perp of the electrode relay in the right order.

5. Electrical connection

For the connection between electrode and electrode relay, we recommend the use of standard control cables that meet the electrical, chemical and mechanical requirements.

6. Triggering of the alarm signal

The output relay is energised when the supply voltage is present and the electrode rods are dry or if rainwater is in contact with the electrode rods. This switching status is the "OK" status. The green LED is lit.

The activated NO contact of the output relay can be used as a quiescent contact in a quiescent current loop.

If the electrode rods come into contact with a leakage liquid that has a far higher electrical conductivity, the output relay is de-energised. This switching status is the "Alarm" status. The red LED lights up.

This switching status corresponds to the switching status in the event of a power failure.

7. Self-hold function

In some cases, it is a good idea to keep an alarm event stored even after the cause of the alarm is no longer present.

To do this, make a connection between E0 and E2 at the electrode relay via an NC contact. A switching status caused by a leakage alarm is then retained and can be cancelled once again by opening the NC contact (cancellation of self-hold function, no acknowledgement function).

8. Warning

If the self-hold function described under 7. is used, an alarm status caused by failure of the supply voltage may lead to undefined memory behaviour.

DSTK- $\frac{3}{4}$ " conductive rod electrode for connection to a conductive electrode relay GR 3 or GR 5

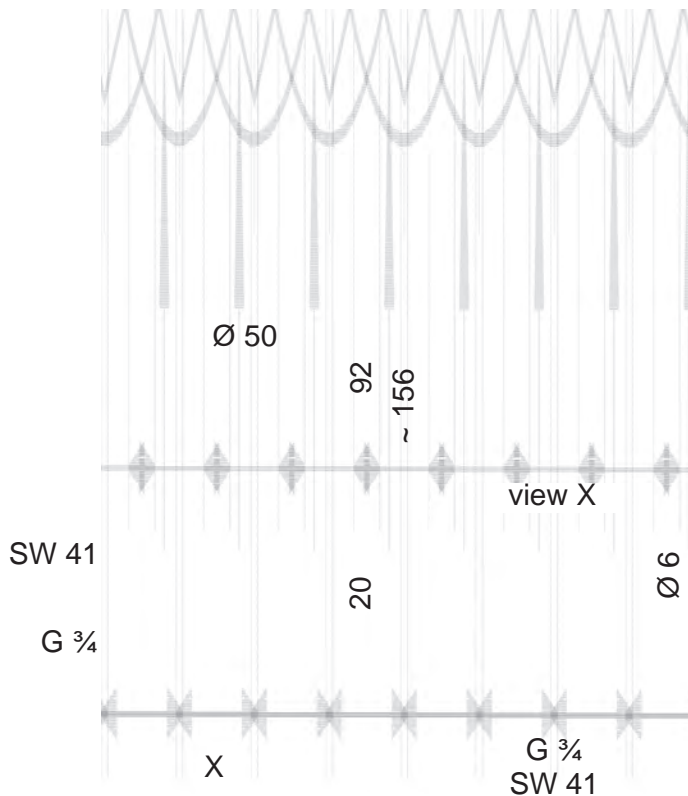

DSTK- $\frac{3}{4}$ " with optional floor stand

The DSTK- $\frac{3}{4}$ " rod electrode is a conductive rod electrode with 2 sensor elements for conductivity measurement in the form of 1 electrode rod made of solid material (for conductivity measurement) and 1 electrode sleeve with integrated temperature sensor (for conductivity measurement and temperature compensation). It serves to generate an alarm signal in the presence of an electrically highly conductive and generally water-polluting leakage liquid.

An integrated resistor circuit suppresses the alarm signal if the detected liquid is only low-conductivity water (e.g. condensation or rainwater).

As the electrical conductivity of liquids is highly dependent on their temperature, the electrode is fitted with a temperature compensation device.

A suitable our electrode relay must be used to ensure safe operation and avoid electric shocks.

Each DSTK- $\frac{3}{4}$ " rod electrode must therefore be connected to a GR 3 or GR 5 electrode relay. You may not connect multiple rod electrodes of the type DSTK- $\frac{3}{4}$ " to one electrode relay.

The connection must be in line with the schematic diagrams on pages 37-3-7 or 37-3-9.

Important notes for safe use

In order to ensure the desired mode of operation, the rod electrode may only be used in cases in which the electrode rods can be reliably covered by the highly electrically conductive liquid to be detected.

Highly electrically conductive residues such as sludge or incrustation can result in permanent activation of the rod electrode.

Technical data	DSTK- $\frac{3}{4}$ "
Application	<p>signalling of an alarm in the presence of an electrically highly conductive (generally water-polluting) leakage liquid. The presence of a liquid with low electrical conductivity (e.g. condensation or rainwater) does not trigger an alarm.</p>
Functional principle	<p>measurement of conductivity with integrated automatic temperature compensation</p>
Sensor elements	<p>1 electrode rod made of solid material (for conductivity measurement) and 1 electrode sleeve with integrated temperature sensor (for conductivity measurement and temperature compensation) made of stainless steel 1.4571, each with 6 mm Ø</p>
Housing	<p>PP, approx. 156 mm (overall length) x 50 mm Ø, potted with polyurethane resin</p>
Screw-in nipple	<p>G$\frac{3}{4}$</p>
Electrical connection	<p>3-wire connection, only suitable for connection to GR 3 or GR 5 electrode relay, with moulded cable, 3 x 0.75 mm², length 2 m, longer connecting cable on request wire colours: brown: electrode alternating voltage supply (E0) black: switching signal (E1) grey: common earth (L)</p>
Mounting orientation	<p>vertical or horizontal</p>
Temperature range	<p>– 20°C to + 60°C, up to + 90°C with reduced temperature compensation</p>
Temperature compensation	<p>compensation by approx. 2.1 %/K across the full temperature application range from – 20°C to + 60°C; compensation falls to approx. 1.5 %/K in the range from + 60°C to + 90°C.</p>
Response sensitivity	<p>response of corresponding GR 3 or GR 5 electrode relay at a value of approx. 1,000 µS/cm of the electrically highly conductive (generally water-polluting) leakage liquid at the DSTK-$\frac{3}{4}$" rod electrode; other response sensitivity on request</p>
Switching delay	<p>in line with the specifications of the corresponding GR 3 or GR 5 electrode relay</p>
Switching status indicator	<p>in line with the specifications of the corresponding GR 3 or GR 5 electrode relay</p>
Optional mounting accessories	<p>screw-on floor stand made of PP, approx. 80 mm Ø x 41 mm, also available with other dimensions between 50 and 150 mm Ø on request</p>

The DSTK- $\frac{3}{4}$ " rod electrode can be screwed into a G $\frac{3}{4}$ thread, attached to an optional floor stand, or suspended from above.

GR 3 conductive electrode relay

for the recognition of a contamination from an electrically highly conductive (generally water-polluting) leakage liquid

Electrode relay for U-bar mounting, with connection terminals on top and with 2 built-in LEDs for signalling the operating status.

This unit is designed for switch cabinet mounting or installation in a suitable protective housing and may therefore only be mounted / installed in these locations. It is suitable for use in clean environments only.

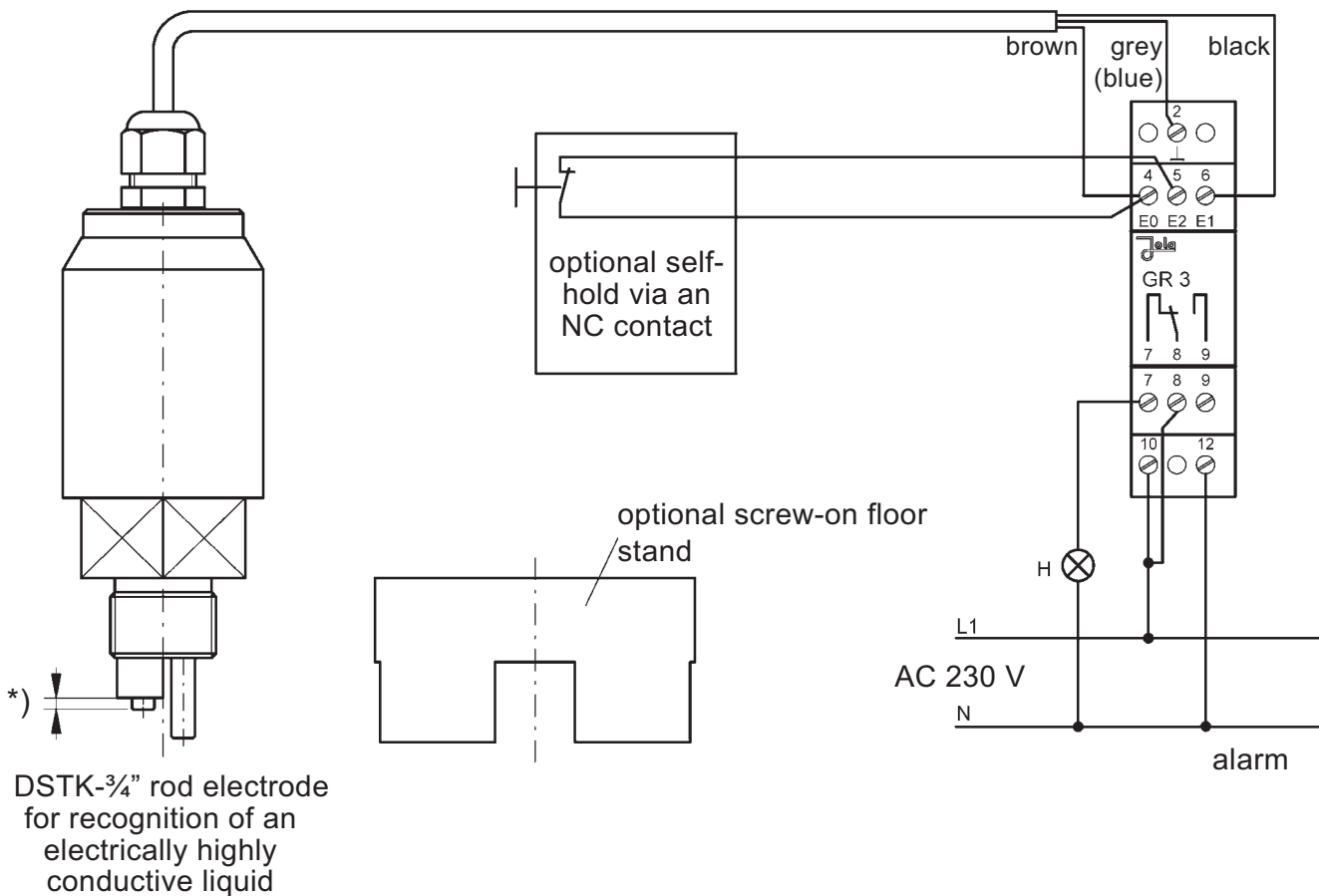

DSTK- $\frac{3}{4}$ " rod electrode for recognition of an electrically highly conductive liquid

*) 1...10 mm for adapted response sensitivity

Technical data	GR 3
<p>Alternative supply voltages (AC versions: terminals 10 and 12; DC versions: • terminal 10: – • terminal 12: +)</p> <p>Power consumption</p>	<p>AC 230 V (supplied if no other supply voltage is specified in the order) or AC 240 V or AC 115 V or AC 24 V or DC 24 V or } in these two cases, the unit must only be DC 12 V or } connected to a low safety voltage which corresponds to the safety regulations relating to the application further supply voltages on request</p> <p>approx. 3 VA</p>
<p>Electrode circuit (terminals 2, 4 and 6)</p> <p>No-load voltage</p> <p>Short-circuit current</p> <p>Response sensitivity</p> <p>Optional self-hold circuit (terminals 4 and 5)</p>	<p>3 terminals (under safety extra low voltage SELV), acting on 1 output relay with optional self-hold</p> <p>9 V_{eff} $\overline{\text{L}}$ 10 Hz (safety extra low voltage SELV)</p> <p>max. approx. 20 mA_{eff} between E0 and \perp</p> <p>response of the GR 3 electrode relay at a value of approx. 1,000 $\mu\text{S}/\text{cm}$ of the electrically highly conductive (generally water-polluting) leakage liquid at the DSTK-$\frac{3}{4}$" rod electrode; other response sensitivity on request</p> <p>A self-hold of an alarm can be realised via a quiescent current loop (pushbutton with NC contact) between E0 and E2. The self-hold can be cancelled by opening the quiescent current loop (by pressing the pushbutton) if the the cause of the alarm is no longer present (cancellation of self-hold function, no acknowledgement function).</p>
<p>Power circuit (terminals 7, 8 and 9)</p> <p>Functioning principle</p> <p>Switching status indication</p> <p>Switching voltage</p> <p>Switching current</p> <p>Switching capacity</p>	<p>1 single-pole potential-free changeover contact with self-hold</p> <p>quiescent current principle</p> <p>1 green LED lights when output relay is energised 1 red LED lights when output relay is not energised</p> <p>max. AC 250 V</p> <p>max. AC 4 A</p> <p>max. 500 VA</p>
<p>Housing</p> <p>Connection</p> <p>Protection class</p> <p>Mounting</p> <p>Mounting orientation</p>	<p>insulating material, 75 x 22.5 x 100 mm, see page 37-3-11</p> <p>terminals on top of housing</p> <p>IP20</p> <p>clip attachment for U-bar to DIN 46277 and EN 50022</p> <p>any</p>
<p>Temperature range</p> <p>Max. length of connecting cable</p>	<p>– 20°C to + 60°C</p> <p>1,000 m between electrode relay and electrode</p>
<p>EMC</p>	<p>for interference emission in accordance with the appliance-specific requirements for households, business and commerce as well as small companies, and for interference immunity in accordance with the appliance-specific requirements for industrial companies</p>

GR 5 conductive electrode relay

for the recognition of a contamination from an electrically highly conductive (generally water-polluting) leakage liquid

Electrode relay for U-bar mounting or surface mounting, with connection terminals on top and with 2 built-in LEDs for signalling the operating status.

This unit is designed for switch cabinet mounting or installation in a suitable protective housing and may therefore only be mounted / installed in these locations. It is suitable for use in clean environments only.

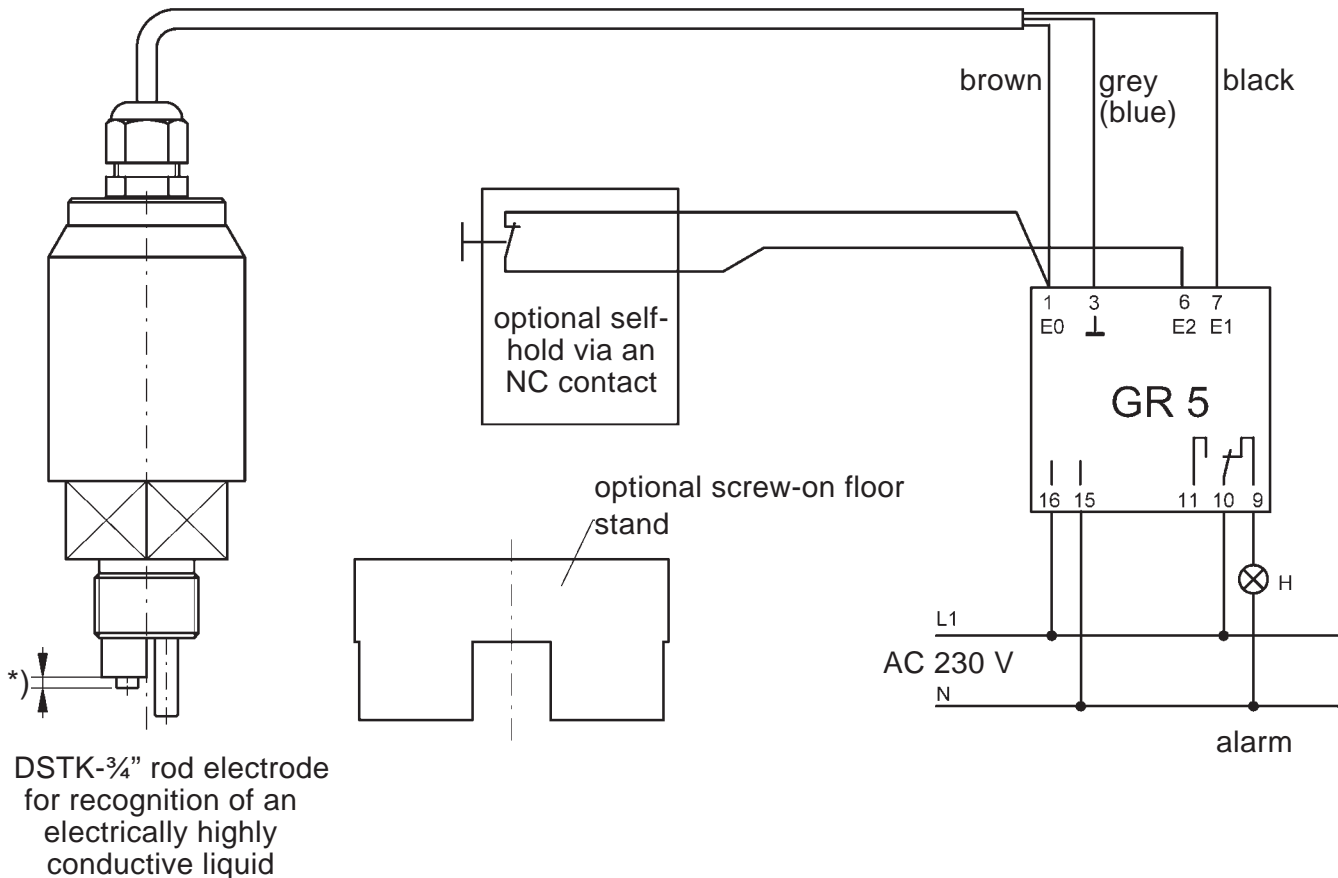

*) 1...10 mm for adapted response sensitivity

Technical data	GR 5
<p>Alternative supply voltages (AC versions: terminals 15 and 16; DC versions: • terminal 15: – • terminal 16: +)</p> <p>Power consumption</p>	<p>AC 230 V (supplied if no other supply voltage is specified in the order) or AC 240 V or AC 115 V or AC 24 V or DC 24 V or DC 12 V or } in these two cases, the unit must only be connected to a low safety voltage which corresponds to the safety regulations relating to the application further supply voltages on request</p> <p>approx. 3 VA</p>
<p>Electrode circuit (terminals 1, 3 and 7)</p> <p>No-load voltage</p> <p>Short-circuit current</p> <p>Response sensitivity</p> <p>Optional self-hold circuit (terminals 4 and 5)</p>	<p>3 terminals (under safety extra low voltage SELV), acting on 1 output relay with optional self-hold</p> <p>9 V_{eff} $\sqrt{10}$ 10 Hz (safety extra low voltage SELV)</p> <p>max. approx. 20 mA_{eff} between E0 and \perp</p> <p>response of the GR 5 electrode relay at a value of approx. 1,000 μS/cm of the electrically highly conductive (generally water-polluting) leakage liquid at the DSTK-$\frac{3}{4}$" rod electrode; other response sensitivity on request</p> <p>A self-hold of an alarm can be realised via a quiescent current loop (pushbutton with NC contact) between E0 and E2. The self-hold can be cancelled by opening the quiescent current loop (by pressing the pushbutton) if the the cause of the alarm is no longer present (cancellation of self-hold function, no acknowledgement function).</p>
<p>Power circuit (terminals 7, 8 and 9)</p> <p>Functioning principle</p> <p>Switching status indication</p> <p>Switching voltage</p> <p>Switching current</p> <p>Switching capacity</p>	<p>1 single-pole potential-free changeover contact with self-hold</p> <p>quiescent current principle</p> <p>1 green LED lights when output relay is energised 1 red LED lights when output relay is not energised</p> <p>max. AC 250 V</p> <p>max. AC 4 A</p> <p>max. 500 VA</p>
<p>Housing</p> <p>Connection</p> <p>Protection class</p> <p>Mounting</p>	<p>insulating material, 75 x 55 x 110 mm, see page 37-3-11</p> <p>terminals on top of housing</p> <p>IP20</p> <p>clip attachment for U-bar to DIN 46277 and EN 50022 or fastening via two boreholes</p>
<p>Mounting orientation</p> <p>Temperature range</p> <p>Max. length of connecting cable</p>	<p>any</p> <p>– 20°C to + 60°C</p> <p>1,000 m between electrode relay and electrode</p>
<p>EMC</p>	<p>for interference emission in accordance with the appliance-specific requirements for households, business and commerce as well as small companies, and for interference immunity in accordance with the appliance-specific requirements for industrial companies</p>

Dimensions

GR 3

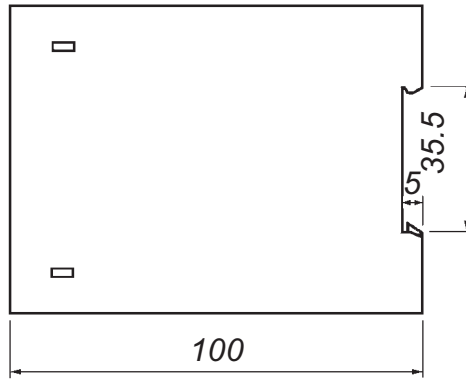
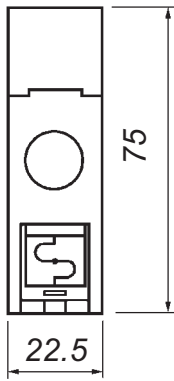

GR 5

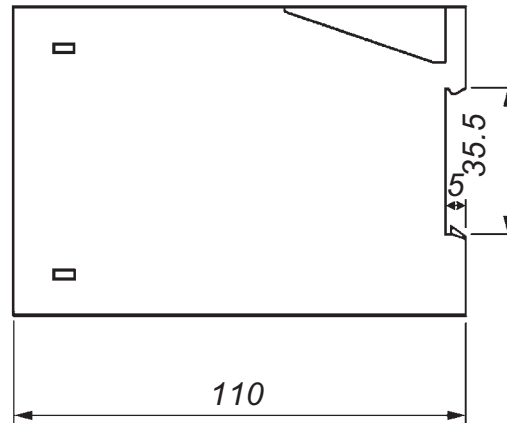
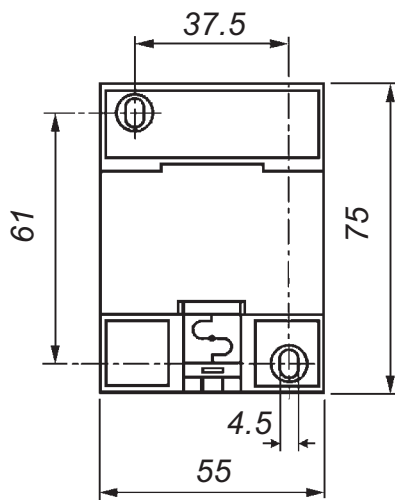

Optional screw-on foot stand for DSTK- $\frac{3}{4}$ "

