

# Capacitive leakage detectors of the LeUk7 UdUWj Y range

with sensor and relay

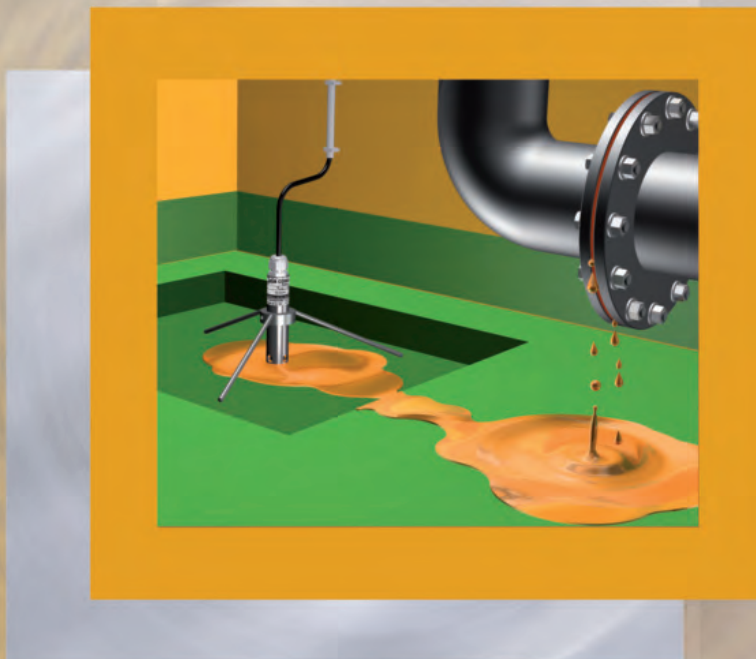

# Capacitive leakage detectors of the LeUk7 UdUWj Y range

## Contents

---

### Capacitive relays

- LeakCapactive 101 31-3-11
- LeakCapactive 155 31-3-13

### Connection box

- DVK 1/5 31-3-18

# Leak7 UdUWj Y 101 capacitive relay

- with DIBt certificate Z-65.40-297

- for connection of 1 DCPE, DOWE 2/C or DCOW capacitive sensor
- with cable break monitoring feature and switchable self-hold
- with 1 potential-free changeover contact at the output

Capacitive relay for DIN rail mounting or fastening via 2 boreholes, with connection terminals on top and with 3 LEDs for signalling the operating statuses

The unit is designed for switch cabinet mounting or installation in a suitable protective housing and may therefore only be mounted / installed in these locations. It is suitable for use in clean environments only.

## Self-hold:

- If the switch for self-hold is switched on, an alarm is stored. The relay continues to signal the alarm even if the cause of the alarm (e.g. the presence of water or a cable break) is no longer present – in other words, if the sensor is dry again or if the line has contact. The alarm is acknowledged by switching off the switch for self-hold.
- If the switch for self-hold is not switched on, the alarm is not maintained when the cause of the alarm has been remedied but is terminated.



Technical data	LeakCapactive 101
Supply voltage (AC versions: terminals 15 and 16, DC versions: • terminal 15: – • terminal 16: +)	AC 230 V, on request: AC 240 V, AC 115 V, AC 24 V, DC 24 V, } only for connection to a safety low voltage DC 12 V } according to the safety regulations relating to the application or further supply voltages
Power consumption	approx. 3 VA
Sensor circuit (terminals 6 and 8)	2 terminals (under safety extra low voltage SELV), acting on 1 output relay with switchable self-hold
No-load voltage	DC 8.4 V (safety extra low voltage SELV)
Short circuit current	< 10 mA
Response sensitivity	1.5 mA $\square$ 1.8 mA
Cable break monitoring	I < 0.15 mA
Power circuit (terminals 9, 10, 11)	1 single-pole potential-free changeover contact based on the quiescent current principle
Switching status indication	via 3 LED (see next page)
Switching voltage	max. AC 250 V
Switching current	max. AC 4 A
Switching capacity	max. 500 VA
Housing	insulating material, 75 x 55 x 110 mm
Connection	terminals on top of housing
Protection class	IP20
Mounting	on 35 mm DIN rail or fastening via two boreholes
Mounting orientation	any
Temperature range	– 20°C to + 60°C
Max. length of connecting cable	1,000 m between relay and sensor
CEM	<ul style="list-style-type: none"> <li>• for interference emission in accordance with the appliance-specific requirements for households, business and commerce as well as small companies</li> <li>• for interference immunity in accordance with the appliance-specific requirements for industrial companies</li> </ul>

# Connection diagram LeakCapactive 101 relay

yellow LED flashes = cable break  
 green LED lights = standby  
 red LED lights = leakage alarm

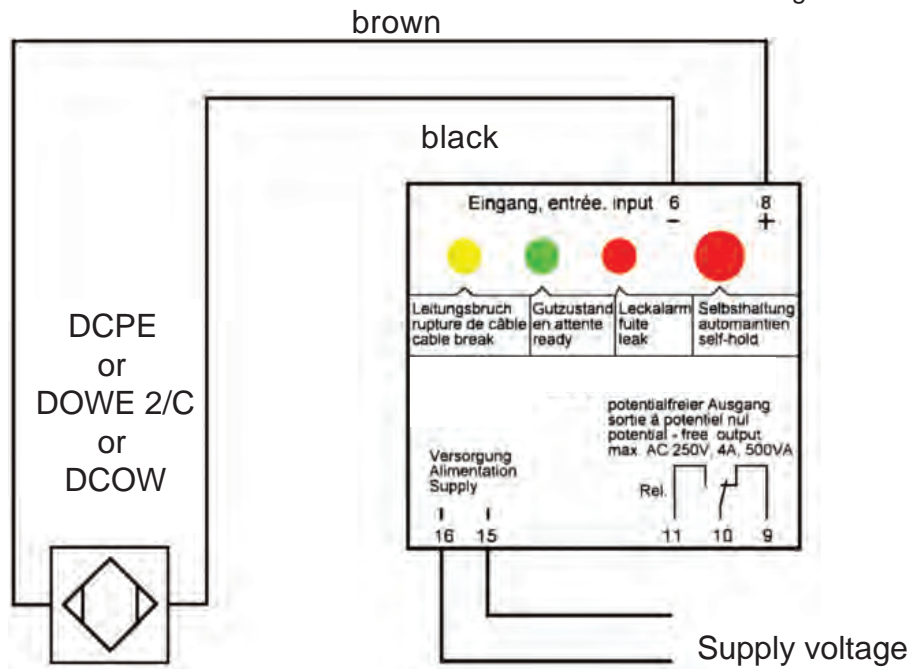

## Position of the output contact of the LeakCapactive 101 relay

**LeakCapactive 101 without voltage**

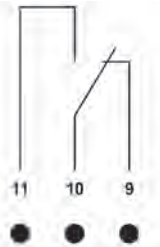

**LEDs dark:**

output relay not energised

**cable break**



**yellow LED flashes:**  
 cable break in sensor or its connecting cable,

output relay not energised

**LeakCapactive 101 under voltage standby**

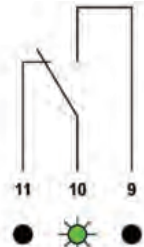

**green LED lights:**  
 sensor not activated,

output relay energised

**leakage**

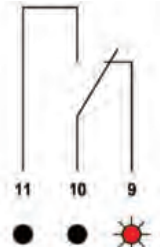

**red LED lights:**  
 sensor activated,

output relay not energised

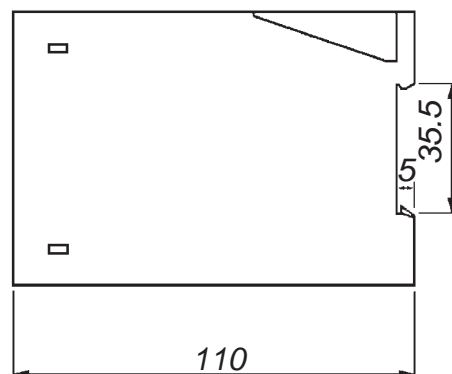
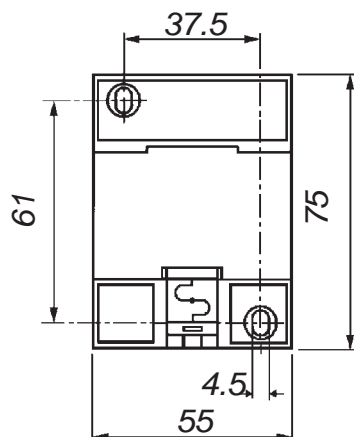

Dimensions in mm

# LeakCapactive 155 capacitive relay

- for the connection of 5 DCPE, DOWE 2/C or DCOW capacitive sensors
- with cable break monitoring feature
- with touch sensor button for alarm acknowledgement
- with 2 potential-free changeover contacts at the output and
- with 5 status signal outputs DC 20 V for the building control system

Capacitive relay in surface-mount housing, with transparent cover, with 5 x 3 LEDs for operating status indication and with 1 LED for acknowledgement status indication, inside the housing



## • Signalling lines

The LeakConductive 155 electrode relay possesses inputs for the connection of 5 signalling lines. Each line allows the connection of one DCPE, DOWE 2/C or DCOW capacitive sensor.

Each capacitive sensor needs a quiescent current to permit cable break monitoring. Each line must therefore be composed of only one capacitive sensor.

The sensor circuits are supplied with a safety extra low voltage generated in the LeakCapactive 155 which is reliably galvanically separated from the mains circuit and the potential-free changeover contacts of the two output relays.

All 5 signalling lines have a common system ground, which means there is no galvanic separation of the signalling lines. This factor must always be taken into account in the case of long signalling lines extending into different parts of the building and in particular with the use of DCOW capacitive sensors and for the detection of conductive liquids.

There is a risk of formation of ground loops if the sensors are mounted in such a way that a sensor can take on ground potential. It may be necessary to perform local potential equalisation in order to avoid potential equalisation currents via the signalling lines.

## • Activation of the individual signalling lines

If not all 5 signalling lines are to be used, the signalling lines 2 to 5 can be activated (dip switch in active position) or deactivated (dip switch in inactive position) individually via 4 dip switches. Channel 1 is always activated.

**Activation / Deactivation may only be performed in currentless status.**

• **Type of indication**

A group of 3 LEDs of different colours is assigned to each signalling line.

<b>Operating status</b>	<b>Type of indication of each signalling line</b>
<b>Power supply</b>	When the supply voltage is switched on, one of the three LEDs on each activated signalling line lights up to indicate the operating status of the activated signalling line in question
<b>Leakage</b>	Red LED lights, if the corresponding activated signalling line reports leakage <ul style="list-style-type: none"> <li>• with effect on the two power circuits</li> <li>• with effect on the corresponding DC 20 V status signal output for the building control system</li> </ul>
<b>Standby</b>	Green LED lights, if the corresponding activated signalling line reports standby <ul style="list-style-type: none"> <li>• with effect on the corresponding DC 20 V status signal output for the building control system</li> </ul> Only if <b>all</b> activated signalling lines indicate standby <ul style="list-style-type: none"> <li>• with effect on the two power circuits</li> </ul>
<b>Cable break</b>	Yellow LED flashes, if the corresponding activated signalling line reports cable break <ul style="list-style-type: none"> <li>• with effect on the two power circuits</li> <li>• with effect on the corresponding DC 20 V status signal output for the building control system</li> </ul>
<b>Signalling line switched to inactive</b>	None of the 3 LEDs in the deactivated signalling line (signalling line 2 to 5) lights up.

• **Power circuits**

Two potential-free changeover contacts are available at the output, one of which reacts based on the working current principle and the other on the quiescent current principle. In addition, there is a DC 20 V binary status output signal based on the quiescent current principle for each signalling line for the building control system. The potential-free changeover contact based on the working current principle can be acknowledged via a touch sensor button acting through the housing cover of the unit.

<b>Power circuits</b>	<b>Switching statuses</b>
<b>Output relay 1 in working current principle</b>	Output relay 1 is not energised in currentless status of the Leak-Capactive 155 and in the standby status of all activated signalling lines. In the event of leakage or cable break in one or more activated signalling lines, output relay 1 is energised if the alarm has not been acknowledged. Output relay 1 can be acknowledged / reset using the touch sensor button.
<b>Output relay 2 in quiescent current principle</b>	Output relay 2 is energised in standby status of all activated signalling lines. Output relay 2 is not energised in currentless status of the LeakCapactive 155 and in the case of leakage or cable break in one or more activated signalling lines.
<b>5 status signal outputs (DC 20 V) for the building control system</b>	A DC 20 V binary switching status output signal in quiescent current principle is available for each of the 5 signalling lines: High signal, DC 20 V = standby status of the activ. signalling line Low signal, DC 0 V = <ul style="list-style-type: none"> <li>• currentless status of the LeakCapactive 155</li> <li>or</li> <li>• leakage or cable break in the activated signalling line or</li> <li>• signalling line that is switched inactive</li> </ul> The 5 outputs are short circuit-protected and have a common reference ground.

Technical data	LeakCapactive 155
Supply voltage (terminals 1 and 2)	AC 230 V, other supply voltage, e.g. DC 24 V, on request approx. 3 VA
Power consumption Sensor circuit (one of the two ground terminals = ground and E1 to E5 = control inputs)	5 terminals under safety extra low voltage, for 5 signalling lines without mutual galvanic separation, with a common ground connection. Connection of the signalling lines is to be made via a 6-core cable and an additional VK 1/5 connection box (see page 31-3-18). Local potential equalisation is to be performed to avoid ground loops in critical installations (see page 31-3-13). DC 8.4 V (safety extra low voltage) < 10 mA 1.5 mA $\square$ 1.8 mA I < 0,15 mA
No-load voltage Short circuit current Response sensitivity Cable break monitoring 1 <sup>st</sup> power circuit (output relay 1 - terminals 3, 4, 5)	1 single-pole potential-free changeover contact based on the working current principle, for group alarm in the event of leakage or cable break, can be acknowledged via the touch sensor button
2 <sup>nd</sup> power circuit (output relay 2 - terminals 6, 7, 8)	1 single-pole potential-free changeover contact based on the quiescent current principle, for group alarm in the event of leakage or cable break
Electrical values of the potential-free changeover contacts: • switching voltage • switching current • switching capacity	max. AC 250 V max. AC 4 A max. 500 VA
Status signal outputs for the building control system (one of the two ground terminals = ground and A1 to A5 = control outputs)	5 terminals under safety extra low voltage for DC 20 V binary switching status output signal of each of the 5 signalling lines, without mutual galvanic separation, with a joint ground connection. <b>For connection to the building control system (e.g. PLC) opto-couplers should be fitted for the purpose of galvanic separation.</b> Standby of the signalling line: High signal (DC 20 V) Leakage/cable break/deactivated line: Low signal (DC 0 V)
No-load voltage Short circuit protection	DC 20 V (sufficient for 24 V inputs, as at least 15 V are normally required for High signal) short circuit current limitation with $\leq$ 30 mA

Technical data	LeakCapactive 155
Switching status indication for the activated signalling lines	optical indication for each of the 5 activated signalling lines by 3 differently coloured LEDs in each case
<ul style="list-style-type: none"> <li>the red LED of one or more signalling lines lights up</li> </ul>	<p style="text-align: center;"><b>Leakage</b></p> <p>output relay 1 is energised (working current principle)  output relay 2 is not energised (quiescent current principle)  output signal of the corresponding signalling line(s) for the building control system is at Low signal (quiescent current principle)</p>
<ul style="list-style-type: none"> <li>the green LED of each signalling line lights up</li> </ul>	<p style="text-align: center;"><b>Standby</b></p> <p>output relay 1 is not energised (working current principle)  output relay 2 is energised (quiescent current principle)  output signals of all signalling lines for the building control system are at High signal (quiescent current principle)</p>
<ul style="list-style-type: none"> <li>the yellow LED of one or more signalling lines flashes</li> </ul>	<p style="text-align: center;"><b>Cable break</b></p> <p>output relay 1 is energised (working current principle)  output relay 2 is not energised (quiescent current principle)  output signal of the corresponding signalling line(s) for the building control system is at Low signal (quiescent current principle)</p>
Housing	insulating material, approx. 180 x 94 x 57 mm,
Connection	with 5 cable entries
Protection class	inside terminals
Mounting	IP54
Mounting orientation	surface mounting using 4 screws
Temperature range	any
Max. length of signalling lines	– 20°C to + 60°C
EMC	each 1,000 m between relay and sensor
	<ul style="list-style-type: none"> <li>for interference emission in accordance with the appliance-specific requirements for households, business and commerce as well as small companies</li> <li>for interference immunity in accordance with the appliance-specific requirements for industrial companies</li> </ul>

### • Acknowledgement via touch sensor button

In the event of leakage or cable break in one of more activated signalling lines, output relay 1 is energised and the red LED on the touch sensor button flashes. The operator has to touch the sensor button panel if he wants to acknowledge the signal. Output relay 1 is then de-energised and the red LED reverts to steady.

In this status, new alarms from other signalling lines are signalled only via the optical indicators and the status signal outputs for the building control system of the affected signalling lines. In these cases, however, output relay 1 is not re-activated.

Acknowledgement has no effect whatsoever on output relay 2.



## Position of the output contacts of the LeakCapactive 155 relay

### LeakCapactive 155 without voltage

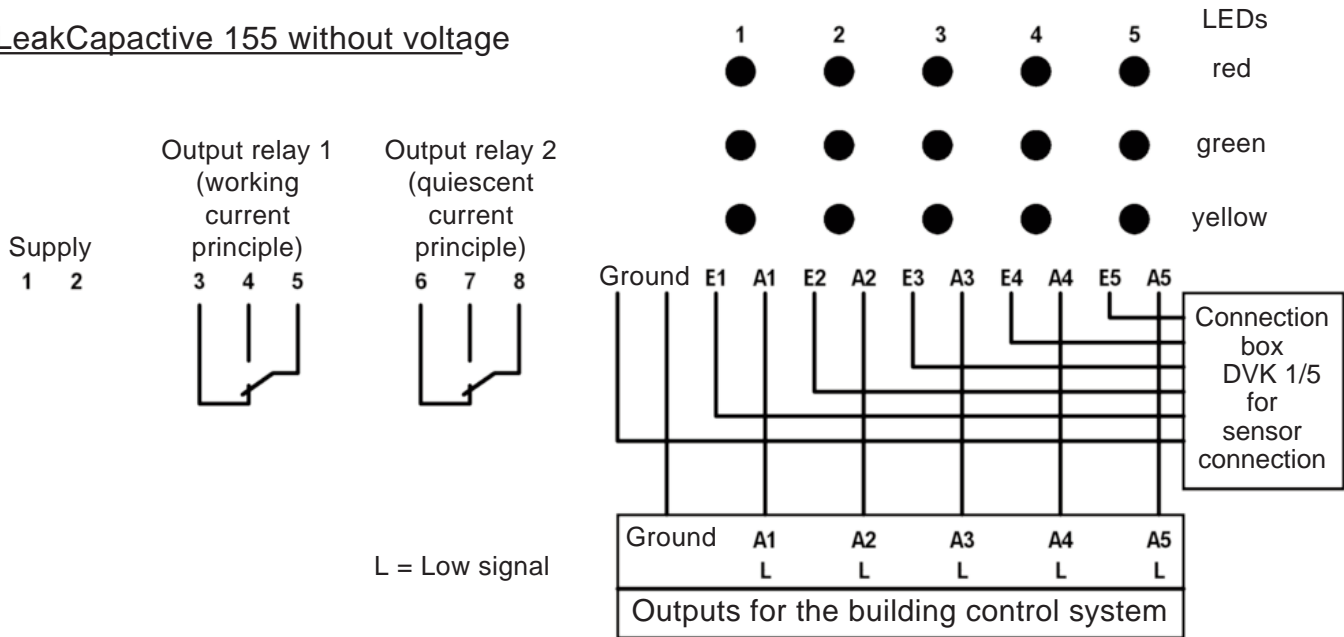

### LeakCapactive 155 under voltage All signalling lines in standby status

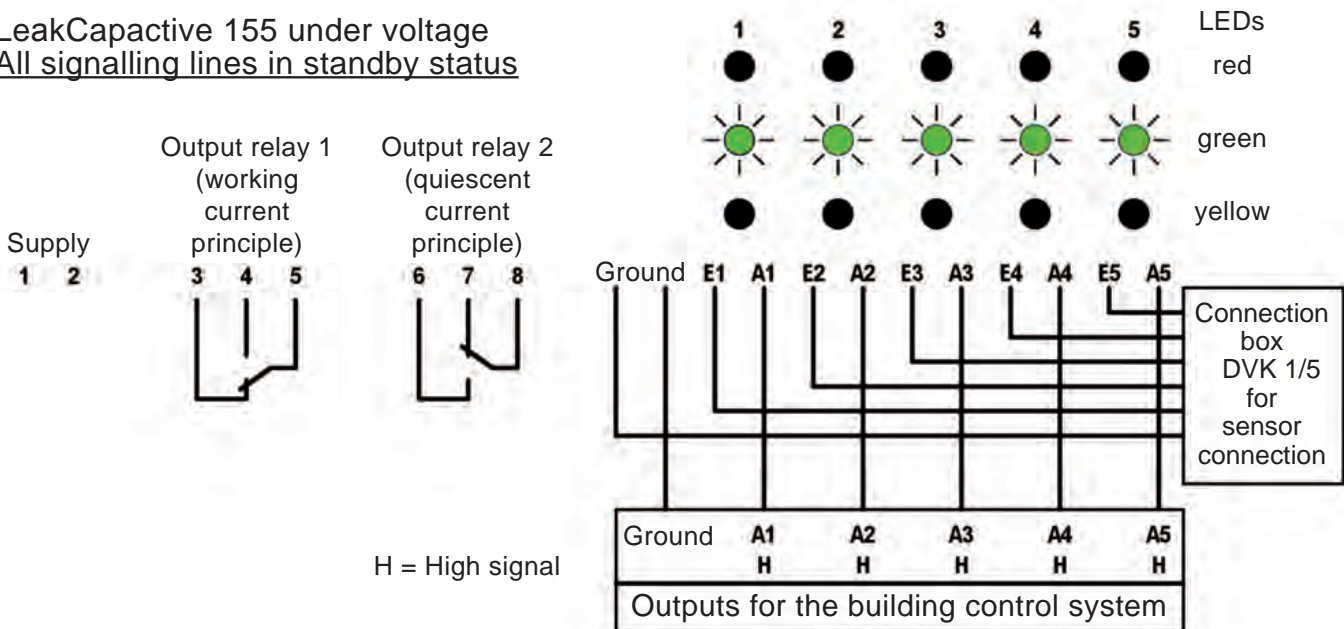

### LeakCapactive 155 under voltage Example: Cable break in signalling line 1 and leakage in signalling line 3

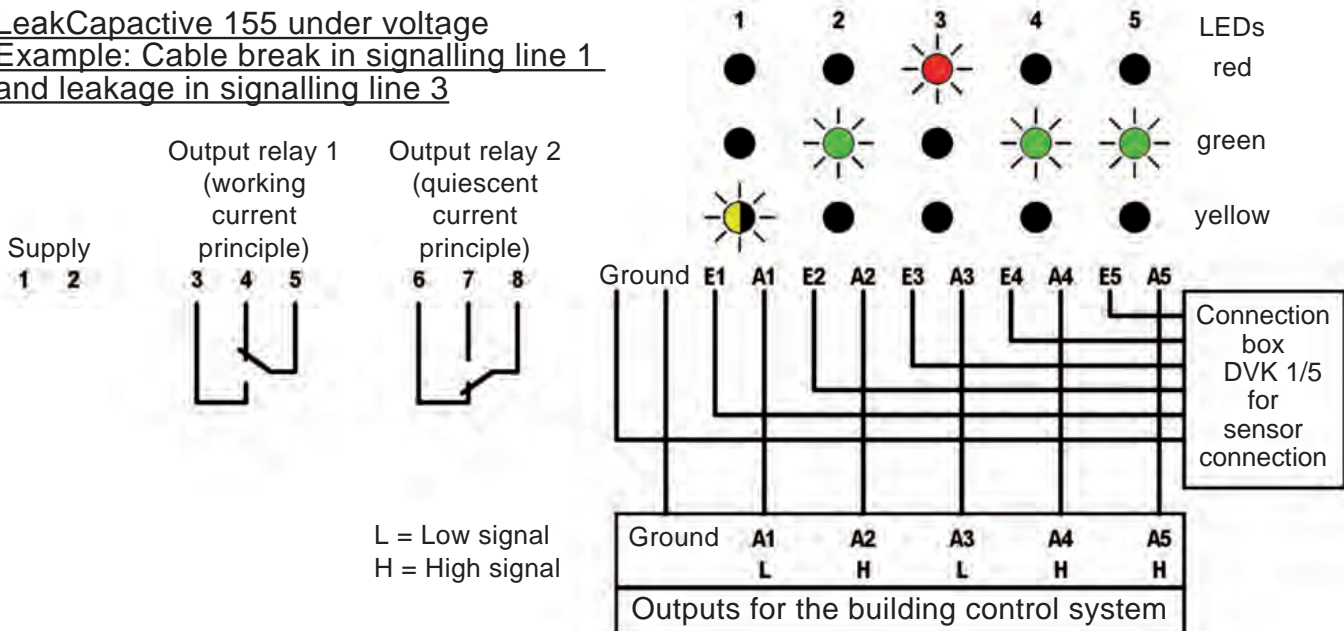

# DVK 1/5 connection box



Technical data	DVK 1/5
Application	for fast and easy connection of up to 5 capacitive sensors to a LeakCapactive 155 capacitive relay
Supply voltage	only for safety extra low voltage SELV or PELV
Housing	insulating material, approx. 180 x 94 x 57 mm, with 6 cable entries
Connection	to the screw terminals on the board
Protection class	IP54
Mounting	surface mounting using 4 screws
Mounting orientation	any
Temperature range	- 20°C to + 60°C

## Dimensions LeakCapactive 155 and VK 1/5

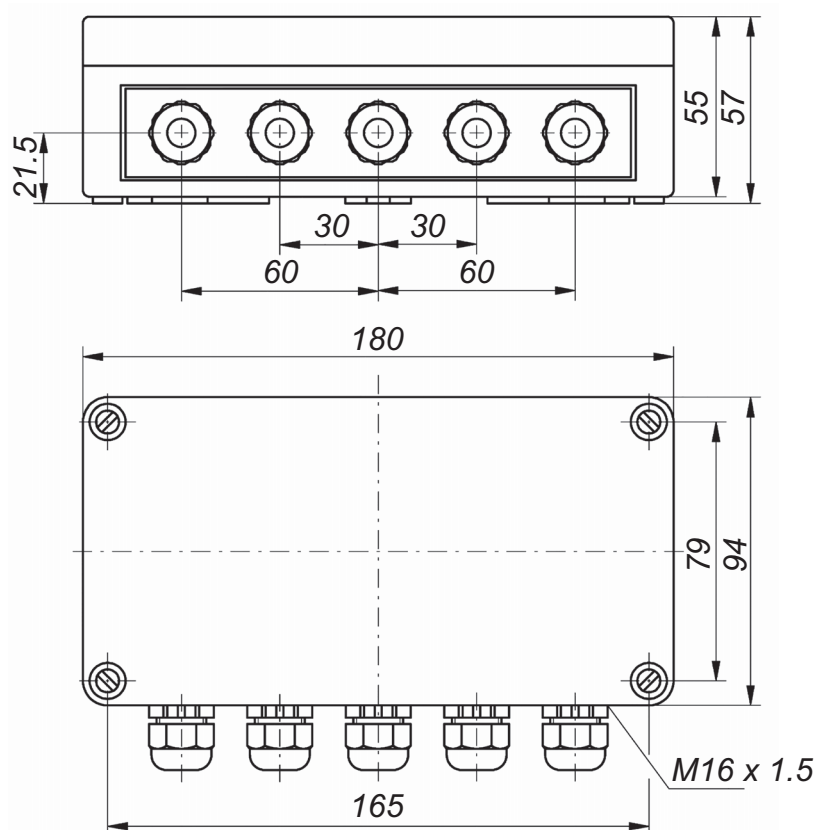

Dimensions in mm

# Example for the connection of electrodes in connection boxes DVK 1/5

Supply      Output relay 1 (working current principle)      Output relay 2 (quiescent current principle)

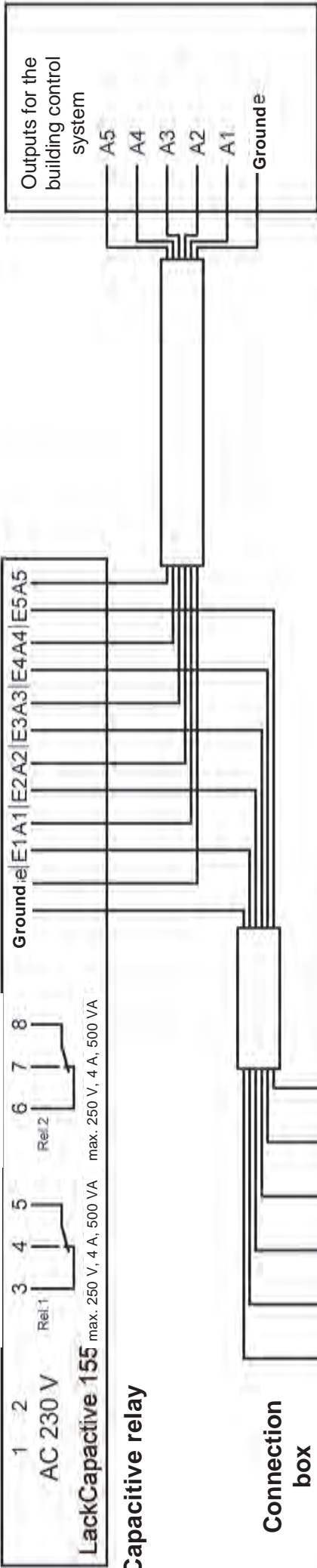

**Capacitive relay**  
 AC 230 V  
 LackCapacitive 155  
 max. 250 V, 4 A, 500 VA      max. 250 V, 4 A, 500 VA

**Connection box**

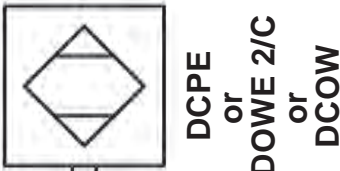
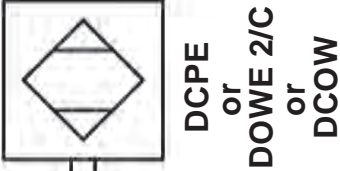
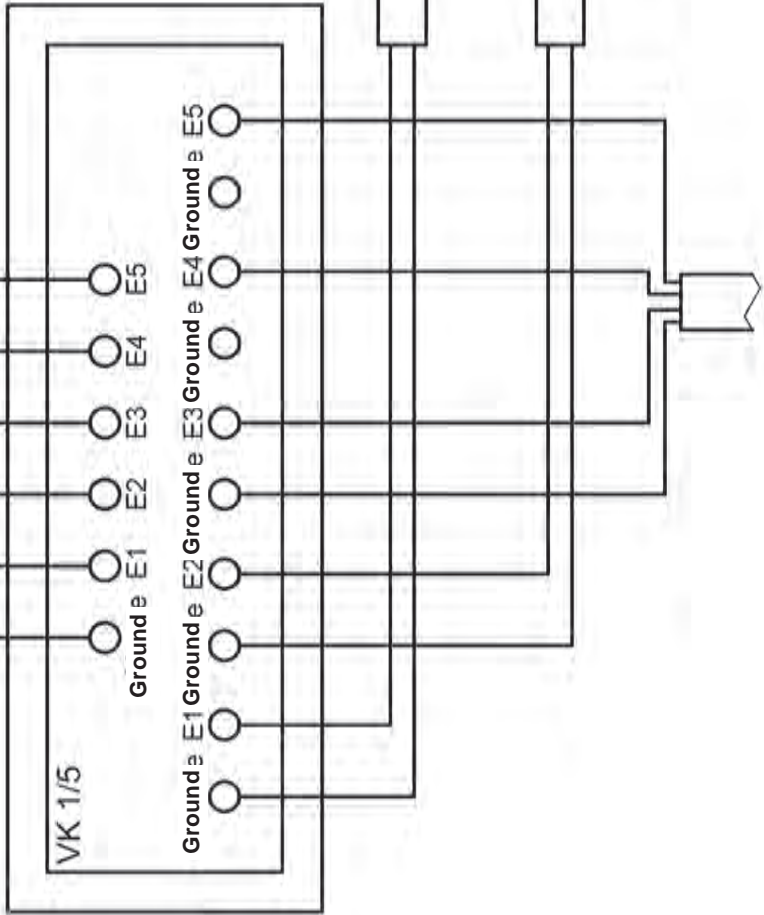

To the next connection box