

CAPACITIVE LEVEL SWITCH CLS-53N

- For limit level sensing of bulk-solid, fragmental and extruded materials
- Simple sensitivity setting by means of magnetic pen
- Two or three-wire connections directly to the relay circuit or PLC logic unit
- Wide range of supply voltage up to 230 V AC/DC (CLS-53N-SAC)
- Optical indication by LED



The capacitive level switch CLS® is designed for limit (2-state) level sensing of bulk-solid materials (pellets, wooden chips, cereals, granulates, etc.) in hoppers, containers, silos, etc. The sensor output is equipped with electronic switch. The sensitivity and output mode (normally open / closed) can be simply set by attaching a magnetic pen to the sensitive spot on the sensor housing.

FEATURES OF VARIANTS

- **CLS-53N-SAC** **2-wire connection** with electronic current switch directly connected to the relay circuit. Supply voltage up to 230 V AC/DC. The sensor is not suitable for direct connection to a binary input of the control system.
- **CLS-53N-P(N)** **3-wire connection** with NPN or PNP output for connected to supply and switching units or binary input of PLC.

TECHNICAL SPECIFICATION

Supply voltage	CLS-53N-SAC	20 ... 230 V AC/DC $\pm 10\%$ 50 ... 60 Hz
	CLS-53N-P(N)	7 ... 36 V DC
Switched current	CLS-53N-SAC CLS-53N-P(N)	min. 4 mA / max. 300 mA max. 200 mA
Supply current - OFF state	CLS-53N-SAC	1.7 mA
	CLS-53N-P(N)	9.0 mA
Output		setting O/C
Max. remanent voltage - ON state	CLS-53N-SAC	max. 6.0 V
	CLS-53N-P(N)	max. 1.5 V
Max. switching frequency		0.5 Hz
Ambient temperature range		-20 ... +60°C
Protection class		IP65
Connection cable type		3 x 1.5 mm ²
Housing material		PP and PVC-U
Weight		approx. 130 g

DIMENSION DRAWING

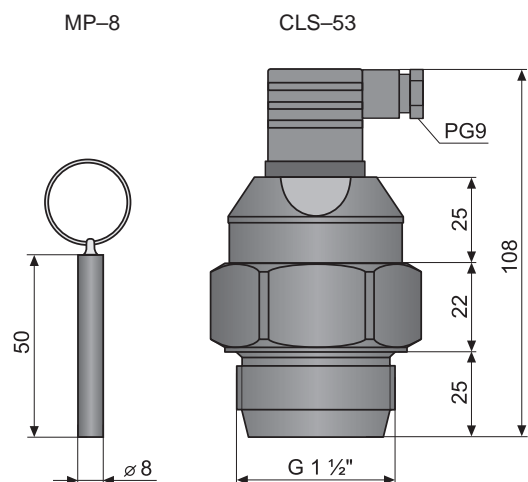

ELECTRICAL CONNECTION

CLS-53N-SAC

Phase conductor (positive supply pole +U in case DC voltage) is connected through the device (relay, contactor) to terminal (1), neutral conductor (N) (negative pole 0V) to terminal (2). The terminal \perp is connected to ground. Connection to supply voltages must be done through fuse or circuit breaker.

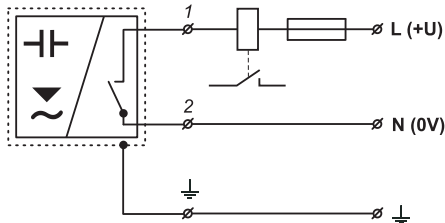

2-wire connection scheme
CLS-53N-SAC

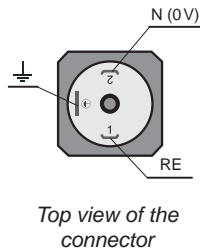
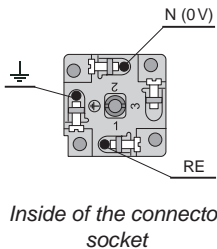

Caution:

The sensor CLS-53N-SAC is not equipped with protection against current overload. Low resistance loads (bulbs) or capacity loads can **damage the sensor!**

CLS-53N-P(N)

Sensor with NPN or PNP output is allowed to lead only by resistive or inductive load. Positive supply voltage (+U) is connected to terminal (1), negative (0V) to terminal (2) and the leads to terminal (3). It is recommended to lead the cable separately from power distribution leads and strong sources of EMI (pulse converters, electric motors etc.).

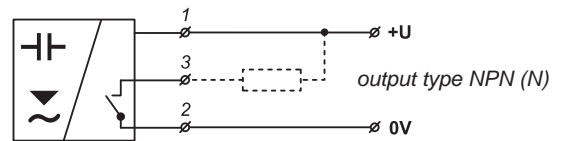
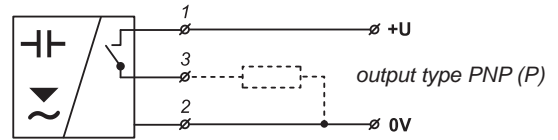

3-wire connection scheme CLS-53N-P(N)

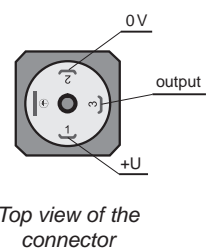
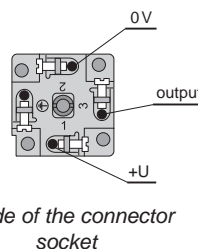

Caution:

The sensor CLS-53N-P(N) is equipped with protection against over-voltages and current overload. The capacity loads and low resistance (bulb) is evaluated by the sensor as short circuit.

MOUNTING RECOMMENDATION

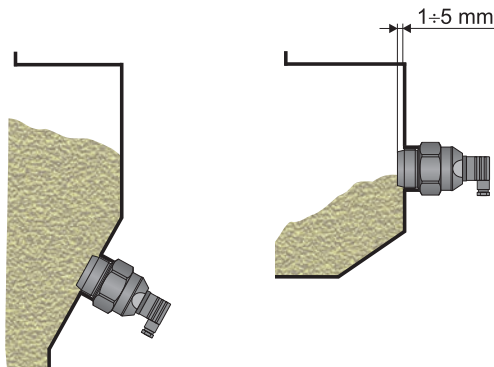

The sensor should be mounted to a slant or vertical wall of the hopper using a welding flange with G1 1/2" thread. The front of the sensor stands 1 to 5 mm behind the inner wall.

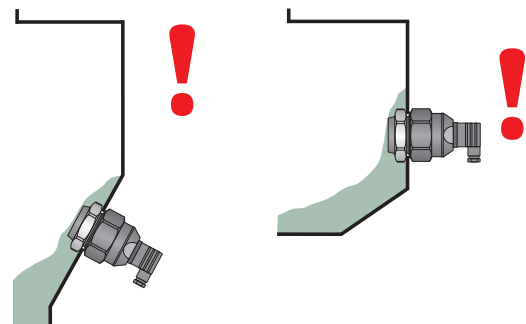

Mounting with the fixing nut for some sticky materials might cause false activation (locking) of the sensor.

SENSOR SETTING

The setting is performed by means of attaching magnetic pen MP-8 to "**SENSE**" spots placed next to the connector and marked with "**set ON**" or "**set OFF**". Such method is used for setting of the sensitivity and the switching mode. The "**mode O**" – normally open (opens when the level drops) and "**mode C**" – normally closed (connects when the level drops). When attaching the magnetic pen to "**SENSE**" spot, LED indicator "**STATE**" shortly flashes four times.

mode O: When the level is low (the container is empty), attach the magnetic pen MP-8 to the "**SENSE**" spot marked with "**set OFF**" for approx. 3 seconds. When the level is high (the container is full), attach the magnetic pen MP-8 to the "**SENSE**" spot marked with "**set ON**" for approx. 3 seconds.

mode C: When the level is low (the container is empty), attach the magnetic pen MP-8 to the "**SENSE**" spot marked with "**set ON**" for approx. 3 seconds. When the level is high (the container is full), attach the magnetic pen MP-8 to the "**SENSE**" spot marked with "**set OFF**" for approx. 3 seconds.

STATUS SIGNALIZATION AND FAILURE ALARM

LED indicator	colour	function
"STATE"	red	Shines – sensor is switched ON Dark – sensor is switched OFF Blinks – sensor did not recognize upper and lower level limit or mistake occurred during setting Four short flashes – attaching the magnetic pen to "SENSE" spot

RANGE OF APPLICATION

Detection of various types of electrically conductive and non-conductive bulk-solid materials (pellets, wooden chips, granulates, cereals, sand, etc.) in various metal and plastic hoppers, containers, and silos.

ORDER CODE

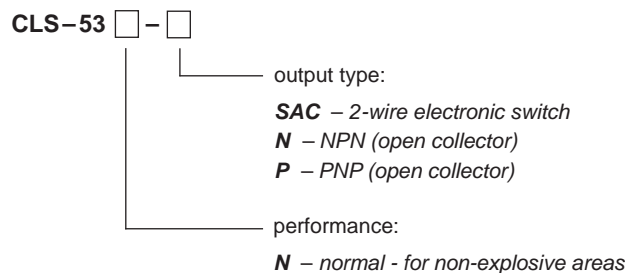

CORRECT SPECIFICATIONS

CLS-53N-SAC

CLS-53N-P

CLS-53N-N

ACCESSORIES

standard – include in the sensor price

- 1 pcs. Magnetic pen MP-8
- 1 pcs. Seal
- 1 pcs. Connector socket with protection class IP65

SAFETY, PROTECTION AND COMPATIBILITY

CLS-53N-SAC:

The sensor is equipped with protection against reverse polarity and short time over-voltages. The sensor is not equipped with protection against current overload. Electrical equipment of protection group II. Electrical safety according to EN 61010-1.

CLS-53N-P(N)

The sensor is equipped with protection against reverse polarity, short time over-voltages and current overload.

For all types:

Electromagnetic compatibility is provided by conformity with standards: EN 55022, EN 61000-6-2, -3, EN 61000-4-2, -3, -4, -5, -6 and EN 61000-4-11.